

A-A (1.5 : 1)

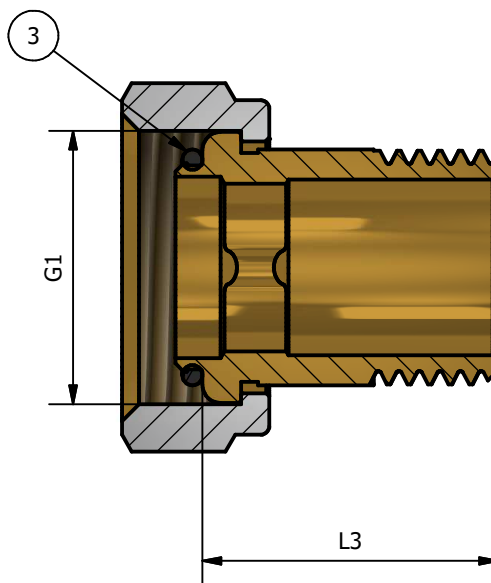

ARTICLE	SIZE	G	G1	L	L1	L2	L3	SW
230 38	3/8x1/2	3/8	1/2	30,5	9,5	13	24	25
230 12	1/2x3/4	1/2	3/4	33	11	13	26	30
230 34	3/4x1"	3/4	1"	37,5	12	15,5	28,5	37
230 01	1"x1"1/4	1"	1"1/4	43	14,5	18	33	46

N°	DESCRIPTION	MATERIAL
1	NUT	CW 617N EN12165
2	TANG	CW 617N EN12165
3	O-RING	NBR
	WORKING PRESSURE MAX	10 BAR
	WORKING TEMPERATURE MAX	95°C

CONFORMITY
1) DM 174 del 6 Aprile 2004
2) UNI EN ISO 681-1
3) UNI EN ISO 228

00	Prima emissione	Delaini M.	29/02/2024
Rev.	Nota Revisione	Approvatore	Data Approvazione
Toll Gen:	JS13	Stato sup.:	Giallo Sabbatiato
Filetto:	ISO 228	Note tecniche:	
Peso lavorato:	Peso grezzo:	N° stampo:	
Materiale:		Disegnatore:	Data: 29/02/2024
		Delaini P.	
Codice: 230 scheda			
Descrizione: Tail and nut with o-ring and conical seat			
TDM Brass s.r.l via Artigiani , 7-9 25030 Maclodio BS Italy tel +39 030 9972217 fax 030 9787089 www.tdmbrass.it email info@tdmbrass.it			

